



Full Length Research Article

SOLAR PV AND BATTERY STORAGE INTEGRATION USING THREE LEVEL NPC INVERTER

*Preethi, L and Ramya Rani

Department of EEE, SKCET, Coimbatore, India

ARTICLE INFO

Article History:

Received 21st January, 2016
Received in revised form
14th February, 2016
Accepted 30th March, 2016
Published online 27th April, 2016

Key Words:

Battery storage,
Solar photovoltaic (PV),
Three port dc to dc converter,
Three-level NPC inverter.

Copyright © 2016, Preethi, and Ramya Rani et al. This is an open access article distributed under the Creative Commons Attribution License, which permits unrestricted use, distribution, and reproduction in any medium, provided the original work is properly cited.

ABSTRACT

In this paper, a configuration of a three-level neutral point clamped (NPC) inverter that can integrate solar PV with battery storage in a grid-connected system is proposed. This paper illustrates the design of three-port dc-dc converter for stand-alone PV systems based on an improved Flyback-Forward topology. It provides a compact single-unit solution with a combined feature of optimized maximum power point tracking (MPPT), high step-up ratio, galvanic isolation, and multiple operating modes for domestic and aerospace applications

INTRODUCTION

The solar energy is the clean and sustainable energy, with long lifespan and a high reliability. To avoid losses of transmission and contributing reductions to CO₂ emission in urban centers, this system can be located. Stand-alone systems are independent of utility grids and commonly employed for satellites, space stations, unmanned aerial vehicles, and domestic applications. Such systems require storage elements to accommodate the intermittent generation of solar power. Over the years, research effort has been directed toward improving the power conversion efficiency as well as the power density by weight and the power density by volume. Traditionally, the two-port topology utilizes the dual active bridges and the half or full bridges can support the multipoint structure to some extent. A combination of Flyback-Forward converter with full bridge has shown some advantages in zero voltage switching (ZVS) and high conversion ratio for fuel cell applications. A modified half-bridge converter which consists of one PV input port, one bidirectional battery port, and an isolated output for satellite applications. However, in these converters, a multi input-multi-output solution is generally difficult to achieve for power electronic applications [1],[4].

In theory, multiple-input converters (e.g. three-port converters) can provide a single-unit solution interfacing multiple energy sources and common loads. They perform better than traditional two-port converters due to their lower part count and smaller converter size. In particular, the isolated three-port converter (ITPC) has become an attractive topology for various applications owing to their multiple energy source connection, compact structure, and low cost. In this topology, a simple power-flow management scheme can be used since the control function is centralized. A high-frequency transformer, can provide galvanic isolation and flexible voltage conversion ratio. The ITPC is usually integrated into an individual converter such as forward, push-pull, full-bridge, and Flyback converters. The ITPC utilizes the triple active bridges (TAB) with inherent features of power controllability and ZVS. Their soft switching performance can be improved if two series-resonant tanks are implemented. An advanced modulation strategy which incorporates a phase shift (PS) and a PWM to extend the operating range of ZVS.

Nonetheless, the TAB topology suffers from the circuit complexity using three active full bridges or half bridges and the power loss caused by reactive power circulation. Therefore, a Buck-Boost converter is proposed to integrate a three-port topology in the half bridge and to decompose the multivariable control problem into a series of independent single-loop subsystems. By doing so, the power flow in each

*Corresponding author: Preethi, L

Department of EEE, SKCET, Coimbatore, India

loop can be independently controlled. The system is suitable for PV-battery applications since one converter interfaces with the three components of the PV array, battery, and loads. However, in each energy transfer state, current passes through at least five inductor windings, especially under high-switching frequency conditions, giving rise to power loss; its peak efficiency is less than 90% and its power capability is limited by the transformer size. Based on these topologies, a new three-port dc-dc converter is developed in this paper to combine a new ITPC topology with an improved control strategy, and to achieve decoupled port control, flexible power flow, and high power capability while still making the system simple and cheap.

The most commonly used multilevel topology is the diode clamped inverter, in which the diode is used as the clamping device to clamp the dc bus voltage so as to achieve steps in the output voltage. According to the original invention, the concept can be extended to any number of levels by increasing the number of capacitors. Early descriptions of this topology were limited to three-levels where two capacitors are connected across the dc bus resulting in one additional level. The additional level was the neutral point of the dc bus, so the terminology neutral point clamped (NPC) inverter was introduced. However, with an even number of voltage levels, the neutral point is not accessible, and the term multiple point clamped (MPC) is sometimes applied. Due to capacitor voltage balancing issues, the diode-clamped inverter implementation has been limited to the three level. Because of industrial developments over the past several years, the three level inverter is now used extensively in industry application.

Existing System

In the existing system the development of new structures of converters (inverters) with a great performance compared to conventional structures. So, these new technologies of semiconductor are more suited to high power applications and they enable the design of multilevel inverters. The constraints due to commutation phenomena are also reduced and each component supports a much smaller fraction of the DC-bus voltage when the number of levels is higher. For this reason, the switches support more high reverse voltages in high-power applications and the converter output signals are with good spectral qualities. Thus, the using of this type of inverter, associated with a judicious control of power components, allows deleting some harmonics. Among the control algorithms proposed in the literature in this field, the SPWM, appears most promising. It offers great flexibility in optimizing the design and it is well suited for digital implementation.

It also helps to maximize the available power. The main advantage of multilevel inverters is that the output voltage can be generated with a low harmonics. Thus it is admitted that the harmonics decrease proportionately to the inverter level. For these reasons, the multilevel inverters are preferred for high power applications. The disadvantages of multilevel inverter is their control is much more complex and the techniques are still not widely used in industry. Several schemes have been proposed to solve these problems. In most DFIG-based WECSs, the load or grid is directly connected to

the stator of the DFIG, and the rotor injection is controlled using an ac-dc-ac converter. Instead of two back-to-back converters, a diode rectifier followed by an inverter can also be used. For systems with only rotor-side converter, pulse width modulation (PWM) converters are used where the grid side PWM rectifier is controlled to provide a constant dc link voltage and the rotor side PWM inverter controls the generator to provide required real and reactive power. In these schemes, the mechanical and electrical frequencies are decoupled making variable speed operation possible. Back to back multilevel inverters were also tried by some researchers for higher capacity installation.

Proposed topology to integrate solar pv and battery storage and its associated control

Proposed Topology to Integrate Solar PV and Battery

Storage Using an Three-Level Inverter

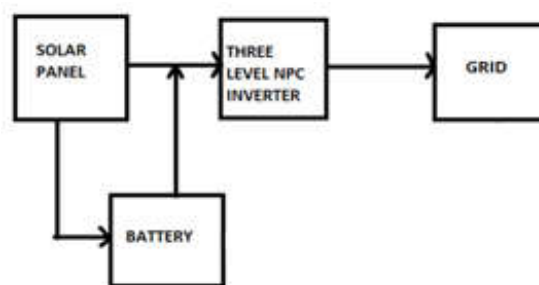

FIG.1 General diagram of a grid connected three-wire three-level inverter

The solar panel output is given to the dc to dc converter and then the battery is integrated and then the inverter is connected to the grid. The output of the panel is given to the dc to dc converter and if the output of the panel is high then it is given to the battery as well as the inverter if the panel output is low then the battery will supply the inverter. The battery will also charge when the panel output is high. The solar panel used here is msx 60 pv panel, the converter used is the three port dc to dc converter and the battery used is nickel metal hydride and the inverter is the three level neutral point clamped inverter (NPC) and then it is connected to the grid.

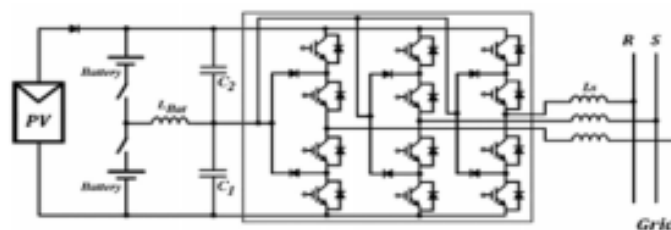

Fig. 2. Circuit Diagram

The battery are connected across two capacitors through two relays. When one of the relays is closed and the other relay is open, during that period the battery can charge or discharge while the renewable energy source can generate power. However, when the renewable energy is unavailable, both relays can be closed allowing the dc bus to transfer or absorb active and reactive power to or from the grid [9]. It should be

noted that these relays are selected to be ON or OFF as required; there is no PWM control requirement. This also provides flexibility in managing the battery and it is to be charged when power is available from the renewable energy source or from the grid. When the battery is fully charged, the relay can be opened, the battery will be supplied to the inverter from the inverter the power will be transferred to the grid. Special consideration needs to be made to ensure that current through the inductor L_{batt} must be zero prior to opening any of these relays to avoid disrupting the inductor current and also to avoid damaging the relay.

Control Topology

The three port dc to dc converter is used for charging and discharging the battery it act as buck boost converter. The converter can provide a high step-up capability for power conversion systems including the PV array, the battery storage, and the isolated load consumption [3]. The primary side of the proposed converter is equivalent to a bidirectional Buck–Boost converter, while the secondary side is a Buck converter in DCM. The output voltage can be controlled by PS on the primary side bridge arm, which can be approximated to adjust the duty cycle of Buck converter of secondary side to realize output voltage regulation. In addition to galvanic isolation, the three-port triple-active-bridge (TAB) converter topology has the advantage of easily matching different port voltage levels in the overall system. This can be done just by choosing the appropriate numbers of turns for the windings. This circuit allows a fixed frequency operation and utilization of the leakage inductance of the transformer as the energy transfer element. Each bridge generates a high-frequency voltage (square-wave in the simplest case) with a controlled phase shift angle with respect to the primary side [15]. The voltages presented to the windings have the same frequency. power flow between the three ports can be controlled by the phase shifts.

The maximum possible power flow is determined by the leakage (and externally added) inductances. This circuit can be operated with soft-switching, provided that the operating voltage at each port is kept near constant. However, when the port operating voltage varies widely, such as with super capacitors, the soft-switched operating range will be reduced. A method has been proposed to extend the soft-switching range by adjusting the duty ratio of the voltage (a rectangular-pulse wave) inversely proportional to the operating voltage of the port.

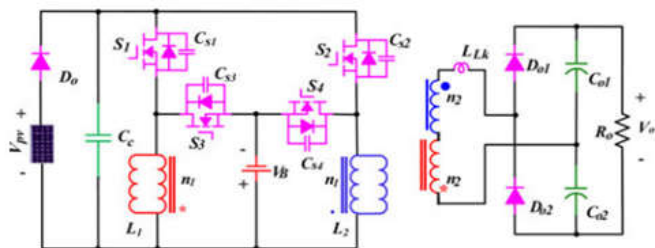

Fig. 3. Three port DC-DC converter

The proposed converter topology is illustrated in the above Figure (15). The main switches S1 and S2 transfer the energy

from the PV to the battery or load, and can work in either interleaved or synchronous mode. The switches S3 and S4 are operated in the interleaved mode to transfer energy from source to load. L1 and L2 are two coupled inductors whose primary winding (n_1) is employed as a filter and the secondary windings (n_2) are connected in series to achieve a high-output voltage gain. LLK is the leakage inductance of the two coupled inductors and N is the turns ratio from n_2/n_1 . CS1, CS2, CS3, and CS4 are the parasitic capacitors of the main switches S1, S2, S3, and S4, respectively.

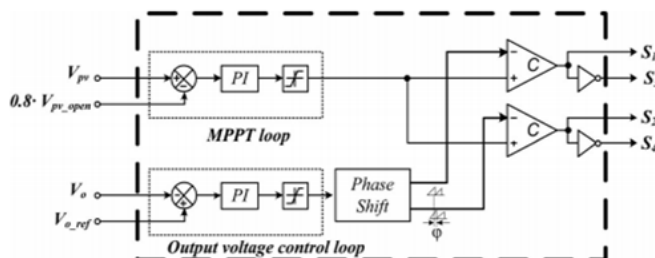

Fig. 4. Diagram of the proposed control scheme

The maximum power point tracking (MPPT) [6] can be implemented by adjusting the duty cycle of switching devices. In the MPPT loop, the PV voltage is regulated to follow an optimal operating point, which is initially assigned to 80% of the open-circuit voltage of the PV array [6]. This point can be determined by the outer MPP Tracker. Moreover, the PV voltage regulation loop is used to improve the MPPT performance. In the output voltage control loop shown in Fig.8 the phase angle of the modulation carrier is the control variable, which regulates the output voltage to follow the expected voltage.

Modeling of pv panel with its basic equation

PV Panel Design

MXS 60 PV Module is taken as the reference module for simulation and the data sheet details are given in TABLE I. In addition to that, series resistance (R_s) of PV module is taken as 0.2Ω , band gap energy (E_g) of the semiconductor used is taken as 1.1 eV and ideality factor(A) of semiconductor is taken as 1.6. Maintaining the Integrity of the Specifications [2].

Table 1. Key specification of mxs 60 pv module

PV module Parameter	Variable	Value
Maximum power	P_m	60W
Maximum voltage	V_m	17.1 V
Current at max power	I_m	3.5 A
Open circuit voltage	V_{oc}	21.06 V
Short circuit current	I_{sc}	3.74 A
Total No. of cells in Series	N_s	36
Total No. of cells in Parallel	N_p	1

Equivalent Circuit of PV module

The ideal equivalent electrical circuit of a solar cell can be represented by a light generated current source, I_{ph} , in parallel with a single-diode as shown in fig. R_s and R_{sh} are the series and shunt resistance of solar cell and they are usually

neglected to simplify the analysis as the value of Rsh is very large and that of Rs is very small.

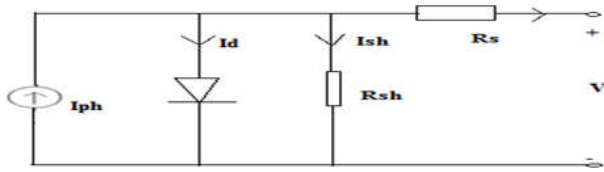

Fig.5 Equivalent circuit of Solar Cell

Usually the output power of a solar cell is very less and of no practical use unless it is increased by some means. So in order to increase the output power of solar PV systems, the solar cells are connected in series and parallel configurations to form solar PV modules and arrays.

Light Generated Photocurrent

The module photocurrent depends linearly on the solar irradiation level and is also influenced by the temperature according to the following equation

$$I_{ph} = [I_{sc} + K_i(T - T_r)] * \lambda \dots\dots\dots(1)$$

Where, I_{sc} is the cell short-circuit current at a 25 °C and 1 kW/m²; K_i is the cell short-circuit current temperature coefficient; T is cell working temperature; T_r is the cell reference temperature and λ is the solar irradiance level in kW/m²

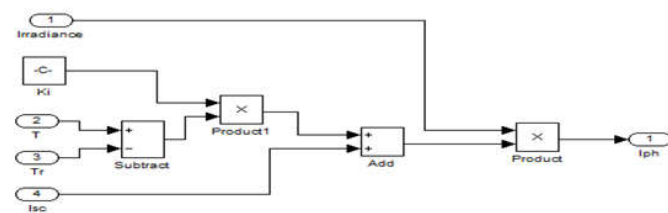

Fig. 6. Simulink model of photocurrent

Model of Temperature Conversion

The temperature used in the mathematical equations of solar PV module is in Kelvin units, figure 3 is to convert the operating temperature from degree Celsius units to Kelvin units using the following equation.

$$T(k) = T(^{\circ}c) + 273 \dots\dots\dots(2)$$

Where, T(K) is temperature in Kelvin and T(°C) is temperature in degree Celsius.

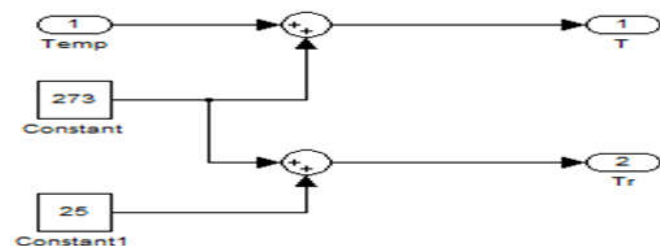

Fig. 7. Simulink model of the temperature conversion from degree Celsius unit to Kelvin unit

Structure of a Three Level Inverter

The three-level inverters are introduced in 1981, Problem of 2-level inverter in high-power applications are High DC link voltage requires series connection of devices difficulty in dynamic voltage sharing during switching these problems are Solved using NPC inverter or multilevel inverter [13].they have been widely used in several applications, such as: motor drives, STATCOM, HVDC, pulse-width modulation (PWM) rectifiers, active power filters (APFs), Multi Megawatt induction /synchronous motor drives for industrial applications and renewable energy applications. Fig.4 shows a typical three-phase three-level NPC inverter circuit topology [13],[12].

The converter has two capacitors in the DC side to produce the three-level AC side phase voltages. DC link capacitor split to create neutral point 0 [12]. Normally, the capacitor voltages are assumed to be balanced, since it has been reported that unbalance capacitor voltages can affect the AC side voltages and can produce unexpected behavior on system parameters such as even-harmonic injection and power ripple. Several papers have discussed methods of balancing these capacitor voltages in various application.

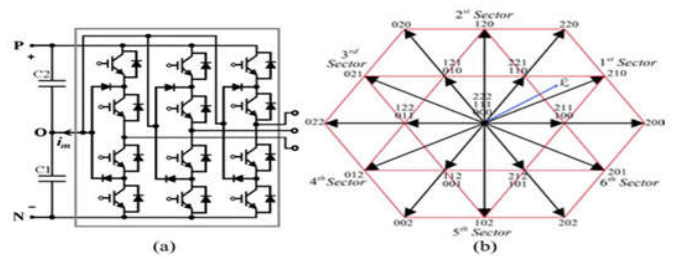

Fig. 8. A typical three-level inverter (a) structure of circuit, and (b) three-level inverter space vector diagram for balanced DC-link capacitors

Simulation and validation of the proposed topology and control system

Simulations have been carried out using MATLAB/Simulink to verify the effectiveness of the proposed topology and control system

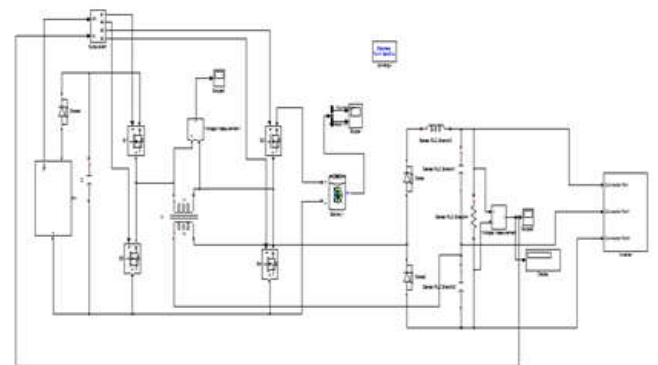

Fig. 9. Simulink Model Of Solar PV and Battery Storage Integration Using Three Level NPC Inverter

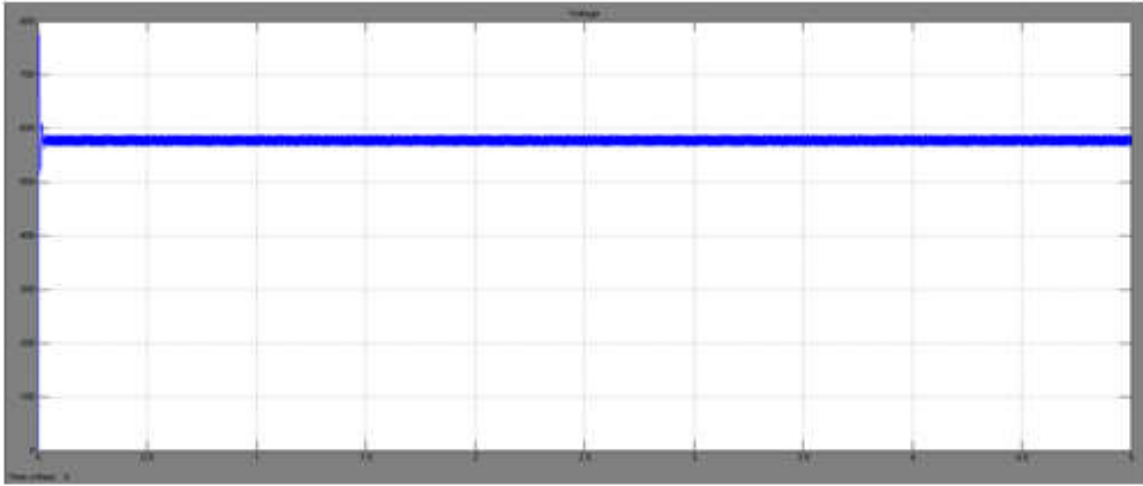

Fig.10. Output Voltage of Battery

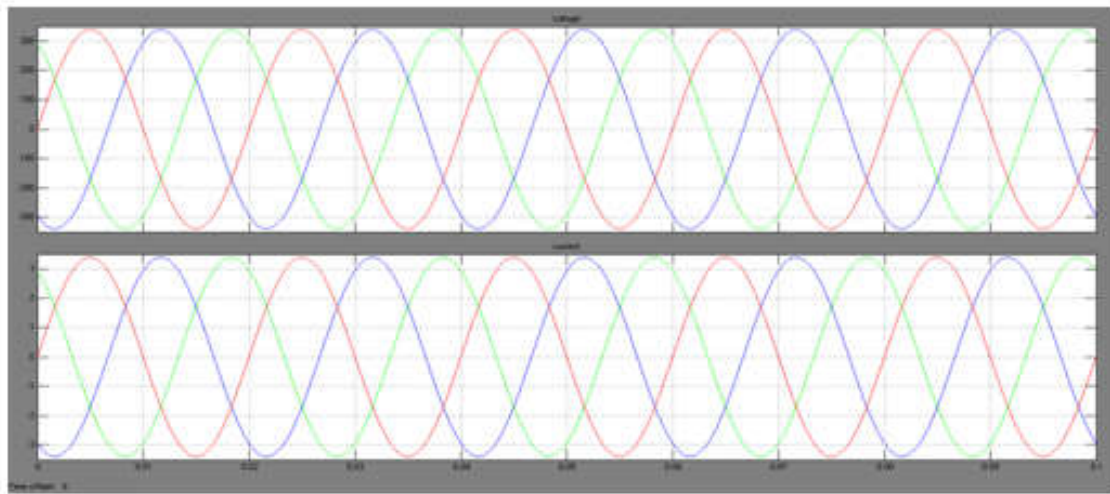

Fig.11. Output Voltage and Current of Inverter

Table 2. Simulated Output voltage

S.No	Components	Practical value
1	Pv panel	24v
2	Converter	576.5 v
3	Inverter	230v

The solar pv and battery integration using npc inverter the pv panel is mxs 60 pv the output of pv 24v and is given to the converter the converter is three port dc to dc converter this converter act in buck mode as well as in boost mode and with that battery is connected. The converter switching operation are done by the mppt the technique used in mppt is frequency division method. The output of the converter is given to the inverter that generates the ac waveform with the output voltage 230v.

Conclusion and future work

In existing system multilevel inverter is used in that there are some disadvantage the control is much more complex and the techniques are still not widely used in industry.

This disadvantages are reduced by three level NPC inverter A three level voltage source inverter that can integrate with both renewable energy and battery storage on the dc side of the inverter. A extended unbalance three-level vector modulation technique that can generate the correct ac voltage under unbalanced dc voltage conditions has been proposed. A new control algorithm for the proposed system has also been presented in order to control power flow between solar PV, battery, and grid system, while MPPT operation for the solar PV is achieved simultaneously. The proposed topology and control algorithm was tested using MATLAB and results are presented. In the results the proposed system is able to control ac-side current, and battery charging and discharging currents at different levels of solar irradiation. The future work is to use five level NPC inverter that can reduce the harmonics in the ac voltage.

REFERENCES

- Basu, K. and Mohan, N. 2014. "A high-frequency link single-stage PWM inverter with common-mode voltage suppression and source-based commutation of leakage energy," IEEE Trans. Power Electron., vol. 28, no. 8, pp. 3907– 3918, Oct.

- Bragard, M., Soltan, N., Thomas, S. et al., 2010. "The Balance of Renewable Sources and User Demands in Grids: Power Electronics for Modular Battery Energy Storage Systems," *IEEE Transactions on Power Electronics*, vol. 25, pp. 3049-3056.
- Hamid R., Teymour, Danny Sutanto, Kashem Muttaqi, P. Ciufu, 2014. "Solar pv and battery storage integration using three level inverter," *IEEE Trans. on energy conversion*, vol. 29, no. 2 Jun.
- Hu, Y., Deng, Y., Liu, Q., and He, X. 2014. "Asymmetry three-level grid-connected current hysteresis control with varying bus voltage and virtual over-sample method," *IEEE Trans. Power Electron.*, vol. 29, no. 6, pp. 3214–3222, Jun.
- Konstantopoulos, C. and Koutroulis, E. 2014. "Global maximum power point tracking of flexible photovoltaic modules," *IEEE Trans. Power Electron.*, vol. 29, no. 6, pp. 2817–2828, Oct.
- Li, W., Li, W., Xiang, X., Hu, Y., and He, X. 2014. "High step-up interleaved converter with built-in transformer voltage multiplier cells for sustainable energy applications," *IEEE Trans. Power Electron.*, vol. 29, no. 6, pp. 2829–2836, Jun.
- Pou, J., Zaragoza, J., Ceballos, S., Saeedifard, M. and D. Boroyevich, 2012. "A carrier-based PWM strategy with zero-sequence voltage injection for a three-level neutral-point-clamped converter," *IEEE Trans. Power Electron.*, vol. 27, no. 2, pp. 642–651, Feb.
- Rodriguez, J., Bernet, S., Steimer, P. K. and I. E. Lizama, 2010. "A survey on neutral-point-clamped inverters," *IEEE Trans. Ind. Electron.*, vol. 57, no. 7, pp. 2219–2230, Jul.
- Toledo, M., Oliveira Filho, D. and A. S. A. C. Diniz, 2010. "Distributed photovoltaic generation and energy storage systems: A review," *Renewable and Sustainable Energy Reviews*, vol. 14, pp. 506-511.
- Villalva, M. G., Gazoli, J. R. and Filho, E. R. 2009. "Comprehensive approach to modeling and simulation of photovoltaic arrays," *IEEE Trans. Power Electron.*, vol. 24, no. 5, pp. 1198–1208, May.
- Wei-dong, J., D. Shao-wu, C. Liu-chen, Y. Zhang, and Q. Zhao, 2010. "Hybrid PWM strategy of SVPWM and VSVPWM for NPC three-level voltage source inverter," *IEEE Trans. Power Electron.*, vol. 25, no. 10, pp. 2607–2619, Oct.
- Xinchun, L., Shan Gao, J. Li, H. Lei, and Y. Kang, 2011. "A new control strategy to balance neutral-point voltage in three-level NPC inverter," in *Proc. IEEE 8th Int. Conf. Power Electron. ECCE Asia*, May/June, pp. 2593–2597.
- Yazdani, A. and Dash, P. 2009. "A Control Methodology and Characterization of Dynamics for a Photovoltaic (PV) System Interfaced With a Distribution Network," *IEEE Transactions on Power Delivery*, vol. 24, pp. 1538-1551.
- Yazdani, A. and Iravani, R. 2010. *Voltage-Sourced Converters in Power Systems*. New York, NY, USA: Wiley.
- Yazdani, A., DiFazio, A.R., Ghoddami, H., et al., 2011. "Modeling Guidelines and a Benchmark for Power System Simulation Studies of Three-Phase Single-Stage Photovoltaic Systems," *IEEE Transactions on Power Delivery*, vol. 26, pp. 1247-1264.
